

REV.	DESCRIPTION	DATE
A0	New Drawing	2008/07/07
B	更新圖面	2014/09/03

NOTES:

1. ELECTRICAL:

- 1) VOLTAGE CURRENT RATING: 1.0AMP,30V AC;
- 2) INSULATION RESISTANCE: 100MΩ MIN;
- 3) CONTACT RESISTANCE: 50mΩ MAX;
- 4) WITHSTANDING VOLTAGE: 300V AC;
- 5) OPERATING TEMPERATURE:-55°C TO +85°C.

2. Mechanical:

- 1) Mating Force: 30N MAX
- 2) Unmating Force: 7N MIN.
3. DIMENSIONS MARKED "▽" TO BE CHECKED BY Q.C & IPQC.

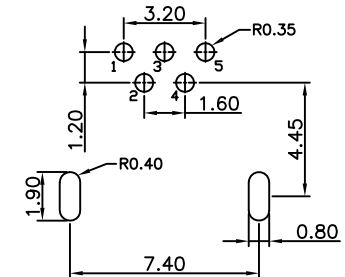
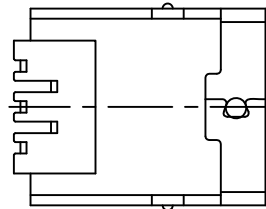
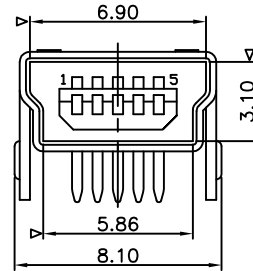
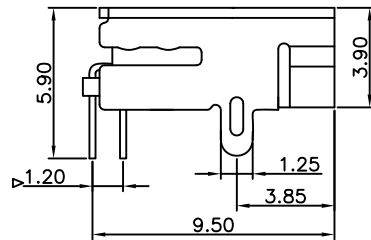
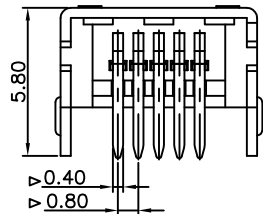
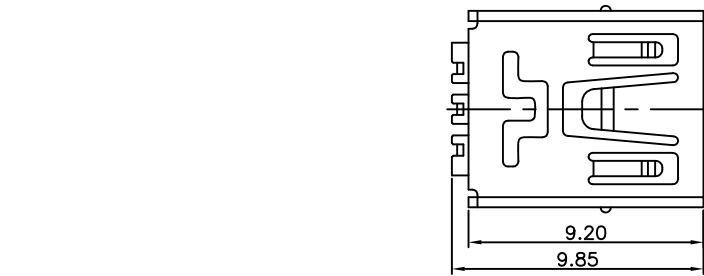

P.C.B LAYOUT

Bill of materials:

NO	PARTS	MATERIAL	QTY	FINISHING
3	HOUSING	LCP	1	UL94V-0
2	SHELL	COPPER ALLOY	1	PLATED NICKEL
1	TERMINAL	COPPER ALLOY	5	PLATED GOLD/TIN

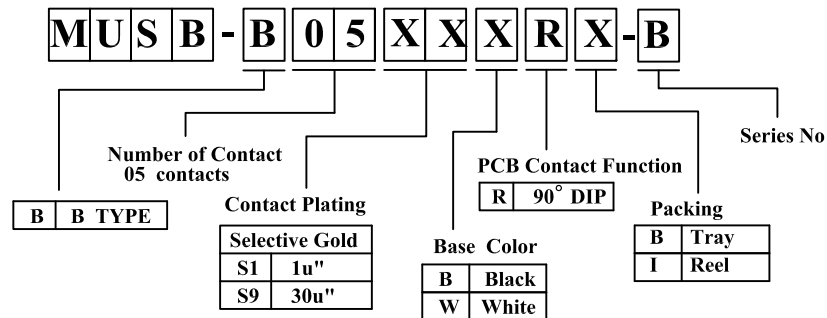

RoHS compliant

竣豪電子股份有限公司
Superior Tech Co., Ltd.

General Tolerance		TITLE	Mini USB Female 5 Pins 90度 DIP(兩雙腳)	
X. ± 0.5		DRAWN	DATE	NO.
.X ± 0.3		Zhanghonglan	09-03-14'	T006
.XX ± 0.2		CHECK	DATE	PART NO.
.XXX ± 0.1		APPROVED	DATE	MUSB-B05XXXRX-B
角度	± 5°			CUSTOMER NO.

REV.	UNIT	SCALE	
B	mm	1:1	

REV.	DESCRIPTION	DATE
A	New Drawing	2014/09/03

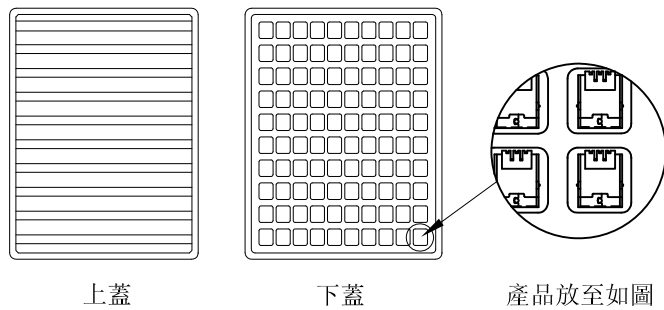

① PE真空盒(1Set)

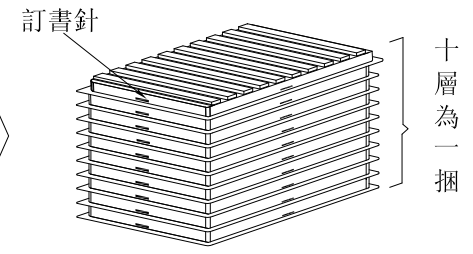
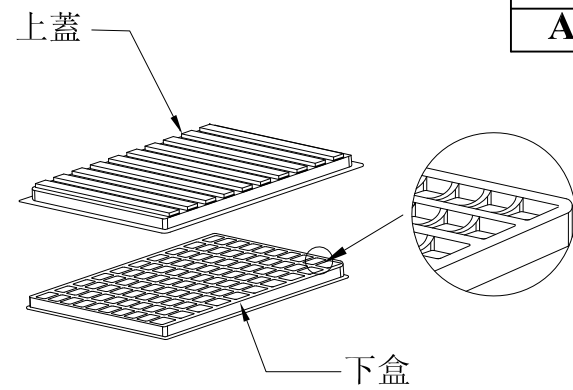

② 100Pcs/盒.

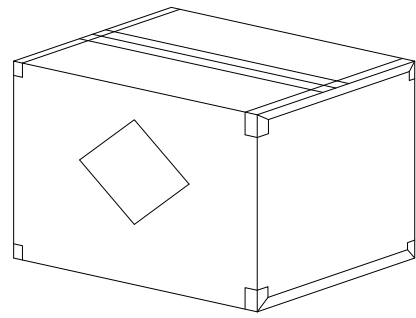

④ 2個內箱/外箱(2K)

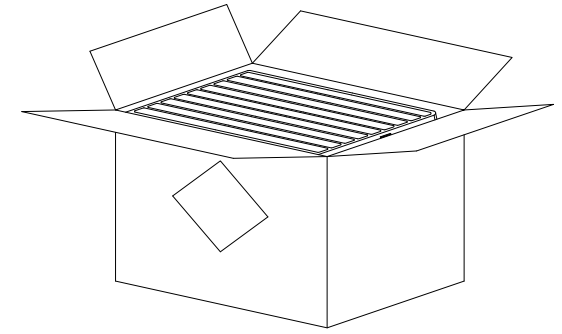

③ 10盒/內箱(1k).

- 備註：
1. 每盒裝成品100Pcs，每箱裝10盒(1000Pcs)；
 2. 外箱尺寸48.5*29.5*28CM；
 3. 產品重量：0.6g/pcs 產品淨重：1.2kg/箱 產品毛重：3.2kg/箱
 4. 出現異常時應及時彙報上級主管.

RoHS compliant

竣豪電子股份有限公司 Superior Tech Co., Ltd.				General Tolerance		TITLE Mini USB Female 5 Pins 90度 DIP包裝圖	
				X. ± 0.5		DRAWN	DATE
REV. A		UNIT mm	SCALE 1:10	Zhanghonglan	2014/09/03	T006	
				CHECK		DATE	PART NO.
				APPROVED		DATE	CUSTOMER NO.
				.XX ± 0.2		MUSB-B05XXXXRX-B	
				.XXX ± 0.1			
				角度	± 5°		